

Article 8. Residential Districts

- 8.1 PURPOSE
 - 8.2 PERMITTED AND CONDITIONAL USES
 - 8.3 BULK AND SETBACK REGULATIONS
 - 8.4 ADDITIONAL SETBACK REQUIREMENTS
 - 8.5 GENERAL STANDARDS OF APPLICABILITY
-

8.1 PURPOSE

A. Purpose of RR Rural Residential District

The purpose of the RR Rural Residential District is to establish and preserve areas within the City where agriculture, very low density development or open space is a current and proper use, but which, in the future, may gradually be required for expansion of urban development as urban facilities and services become available, and preserve said land in agricultural or open space usage and in large parcels until capital funds for the extension of urban facilities and services are committed in an adopted capital improvement program. Although the predominant use within the RR District is intended to be agriculture, other quasi-urban uses are also permitted, including scattered non-farm residences facilitating an orderly transition from agricultural and rural uses to urban uses.

B. Purpose of R-1 Single-Family Residential District

The purpose of the R-1 Single-Family Residential District is to provide for and preserve single-family residential development on larger lots within the City. The R-1 District provides for limited non-residential uses that are compatible with surrounding residential neighborhoods.

C. Purpose of R-1A Single-Family Residential District

The purpose of the R-1A Single-Family Residential District is to provide for and preserve single-family residential development within the City on traditionally smaller lots. The R-1A District provides for limited non-residential uses that are compatible with surrounding residential neighborhoods.

D. Purpose of R-2 Single-Family and Two-Family Residential District

The purpose of the R-2 Single-Family and Two-Family Residential District is to provide for, and preserve, two-family residential development, as well as single-family dwellings. The R-2 District also provides for limited non-residential uses that are compatible with surrounding residential neighborhoods.

E. Purpose of R-3 Lodging House, Fraternity and Sorority House Residential District

The purpose of the R-3 Lodging House, Fraternity and Sorority House Residential District is to accommodate multi-tenant residences in those areas, such as the university neighborhood, where there is demand for these housing types, as well as single-family and two-family residential development. The R-3 District also provides for limited non-residential uses that are compatible with surrounding residential neighborhoods.

F. R-3A General Residential and Lodging House District

The purpose of the R-3A General Residential and Lodging House District is to accommodate multi-tenant residences, as well as single-family, two-family and multi-family residential development. The R-3A District also provides for limited non-residential uses that are compatible with surrounding residential neighborhoods.

G. Purpose of R-4 Townhouse Residential District

The purpose of the R-4 Townhouse Residential District is to provide for, and preserve, single-family, two-family and townhouse residential development, as well as low-rise multi-family dwellings. The R-4 District also provides for limited non-residential uses that are compatible with surrounding residential neighborhoods.

H. Purpose of R-5 General Multi-Family Residential District

The purpose of R-5 Multi-Family Residential District is to provide for, and preserve, quality high density residential development including multi-family dwellings up to four (4) stories. The R-5 District also provides for limited non-residential uses that are compatible with surrounding residential neighborhoods.

I. Purpose of R-6 Multi-Family Residential District

The purpose of the R-6 Multi-Family Residential District is to create a higher density environment of single-family homes, two-family dwellings, townhomes and multi-family dwellings, including limited multi-tenant housing like dormitories. Limited non-residential uses that are compatible with surrounding residential neighborhoods may be permitted.

J. Purpose of R-7 High Rise Multi-Family Residential District

The purpose of the R-7 High-Rise Multi-Family Residential District is to accommodate the highest density residential environment of multi-family dwellings, of significant height, within the City. Limited non-residential uses that are compatible with surrounding residential neighborhoods may be permitted.

8.2 PERMITTED AND CONDITIONAL USES

Table 8-1: Residential Districts Permitted and Conditional Uses lists permitted and conditional uses for the residential districts. A “P” indicates that a use is considered permitted within that district. A “C” indicates that a use is considered a conditional use in that district and must obtain a conditional use permit as required in Section 4.3 (Conditional Use Permit). No letter (i.e., a blank space), or the absence of the use from the table, indicates that use is not permitted within that district.

TABLE 8-1: RESIDENTIAL DISTRICTS PERMITTED AND CONDITIONAL USES											
USES	DISTRICTS										USE STANDARD
	RR	R-1	R-1A	R-2	R-3	R-3A	R-4	R-5	R-6	R-7	
Agricultural Uses ^{1 6}	RR	R-1	R-1A	R-2	R-3	R-3A	R-4	R-5	R-6	R-7	
Agricultural Service Establishment ⁶	C										
Crop, Vegetable and/or Flower Farm: Over 100 acres ²		P	P	P							
Hobby Farm ^{1 6}	P										
Nursery and/or Tree Farm ⁶	P										
Living Quarters for More than 6 Persons Employed On-Premises	P										

TABLE 8-1: RESIDENTIAL DISTRICTS PERMITTED AND CONDITIONAL USES

USES	DISTRICTS										USE STANDARD
	RR	R-1	R-1A	R-2	R-3	R-3A	R-4	R-5	R-6	R-7	
Raising of Livestock (Excludes Fur-Bearing Animals) ^{1 6}	C										
Stable ^{1 6}	C										
Residential Uses	RR	R-1	R-1A	R-2	R-3	R-3A	R-4	R-5	R-6	R-7	
Bed & Breakfast Facility	C ⁶	C	C	C	C	C	C	C	C	C	See Section 14.3.C
Convalescent Home									P		
Dormitory					P				P		
Dwelling, Multi-Family					P	P	P	P	P	P	
Dwelling, Single-Family Detached	P ³	P	P	P	P	P	P	P	P	P	See Section 14.3.H
Dwelling, Townhouse							P	P	P	P	See Section 14.3.H
Dwelling, Two-Family	P			P	P	P	P	P	P	P	See Section 14.3.H
Fraternity/Sorority House					P	P					
Lodging House					P	P					See Section 14.3.N
Manufactured Housing Park	C			C	C	C	C	C	C	C	See Section 14.3.O
Nursing Home									P		
Residential Facility: 6 or Fewer Persons	P	P	P	P	P	P	P	P	P	P	
Residential Facility: 7 to 16 Persons				P	P	P	P	P	P	P	See Section 14.3.T
Residential Facility: 16 or More Persons				C	C	C	C	C	C	C	See Section 14.3.T
Institutional and Public Uses	RR	R-1	R-1A	R-2	R-3	R-3A	R-4	R-5	R-6	R-7	
Club, University-Related: Social or Religious					P	P					
Community Center			C	C	C		C	C	C	C	
Essential Services & Essential Service Structure	P	P	P	P	P	P	P	P	P	P	
Place of Worship	P	C	P	P	P	P	P	P	P	P	See Section 14.3.S
Public Building	P	P	P	P	P	P	P	P	P	P	
Utilities	C	C	C	C	C	C	C	C	C	C	See Section 14.3.X
School	C	C	P	P	P	P	P	P	P	P	
Temporary Shelter Facility		P ⁴	P ⁴	P ⁴	P	P ⁴	P	P	P	P	See Section 14.3.V
University					P						
Open Space Uses	RR	R-1	R-1A	R-2	R-3	R-3A	R-4	R-5	R-6	R-7	
Cemetery/Memorial Garden	P	C	C	C	C		C	C	C	C	See Section 14.3.E
Driving Range		C	C	C			C	C	C	C	
Golf Course		C ⁵	C	C			C	C	C	C	
Public Park/Recreation Area, Athletic Field & Open Space – Owned/Operated by Church Group or Homeowner’s Association	C	C	C	C	C	C	C	C	C	C	
Public Park/Recreation Area, Athletic Field & Open Space	P	P	P	P	P	P	P	P	P	P	
Tennis Club		C	C	C			C	C	C	C	
Commercial Uses	RR	R-1	R-1A	R-2	R-3	R-3A	R-4	R-5	R-6	R-7	
Activity Center			C	C			C	C	C	C	
Commercial Kennel ⁶	C										See Section 14.3.F
Commercial Outdoor Recreation Facility ⁶	C										
Day Care Facility: 12 or Fewer Persons	P ⁶	P	P	P	P	P	P	P	P	P	
Day Care Facility: 13 or More Persons					C	C	C	C	C	C	
On-Site Rental Office					P		P	P	P	P	See Section 14.3.R
Roadside Stand: Sale of Excess Garden Produce ⁶	C										
Veterinary Establishment (Large)	C										

TABLE 8-1: RESIDENTIAL DISTRICTS PERMITTED AND CONDITIONAL USES											
USES	DISTRICTS										USE STANDARD
	RR	R-1	R-1A	R-2	R-3	R-3A	R-4	R-5	R-6	R-7	
Animal) ⁶											
Transportation Uses	RR	R-1	R-1A	R-2	R-3	R-3A	R-4	R-5	R-6	R-7	
Airport		C	C	C			C	C	C	C	
Heliport		C	C	C			C	C	C	C	
Industrial Uses	RR	R-1	R-1A	R-2	R-3	R-3A	R-4	R-5	R-6	R-7	
Mineral Extraction ⁶	C										
Wind Energy Conversion Systems	RR	R-1	R-1A	R-2	R-3	R-3A	R-4	R-5	R-6	R-7	
Building Mounted	P/C ⁸	C ⁷	C ⁷	C ⁷	C ⁷	C ⁷	P/C ⁸	P/C ⁸	P/C ⁸	P/C ⁸	See Section 14.3.Y
Freestanding	P/C ⁸	C ⁷	C ⁷	C ⁷	C ⁷	C ⁷	C ⁷	C ⁷	C ⁷	C ⁷	See Section 14.3.Y

FOOTNOTES TABLE 8-1

- ¹ All properties with livestock must have a Waste Utilization Plan (according to NRCS Standard 633) approved by the applicable county soil and water conservation district and comply with all MPCA permitting requirements.
- ² Subject to species approved by City Park Department. The sale or display of a product or commodity that is readily visible and accessible by non-residents of the property or building are prohibited.
- ³ Maximum of two per zoning lot.
- ⁴ In the R-1, R-1A and R-3A, temporary shelter facilities are limited to serving 4 or fewer persons. In the R-2 District, temporary shelter facilities are limited to serving 6 or fewer persons.
- ⁵ In the R-1 District, a golf course may include an accessory miniature golf course. Unless noted, miniature golf courses are not permitted as part of a golf course.
- ⁶ Maximum building area of three thousand (3,000) square feet of gross floor area.
- ⁷ Allowed only on institutional properties with a Conditional Use Permit. Systems may not exceed 10 kw.
- ⁸ WECS with a rated capacity of 1.8 kw or less are permitted on parcels occupied by a residential or institutional use. WECS between 1.9 kw and 10 kw are allowed on institutional properties with a Conditional Use Permit.

8.3 BULK AND SETBACK REGULATIONS

Table 8-2: Residential Districts Bulk and Setback Regulations establishes bulk and setback regulations for the residential districts.

TABLE 8-2: RESIDENTIAL DISTRICTS BULK AND SETBACK REGULATIONS	
BULK AND SETBACK REQUIREMENTS	DISTRICT
	RR
BULK REQUIREMENTS	
Minimum Lot Area	10 acres
Minimum Lot Width	300 ft
Minimum Lot Depth	300 ft
Maximum Lot Coverage	30%
Maximum FAR	0.6
Maximum Building Height	35 ft
Minimum Driveway Separation (excluding farm field approaches)	300 feet on collector or arterial street
Maximum Animal Density ^{1,2}	.5 equine per acre .5 cattle per acre 1.5 swine per acre 2 cervidae per acre (e.g. deer) 2.5 goats and/or sheep per acre 12.5 large poultry per acre (e.g. turkeys, ducks, etc.) 25 small poultry and animals per acre (e.g. chickens, rabbits, etc.)
SETBACK REQUIREMENTS	
Front Setback	30 ft
Interior Side Setback	Residential use: 10 ft Non-Residential Use: 30 ft

Street Side Setback	30 ft
Rear Setback	30 ft

TABLE 8-2: RESIDENTIAL DISTRICTS BULK AND SETBACK REGULATIONS

BULK AND SETBACK REQUIREMENTS	DISTRICT	
	R-1	R-1A
BULK REQUIREMENTS		
Minimum Lot Area	Single-Family & Day Care Facility: 9,000sf Place of Worship & School: 22,000sf Public Building & Utilities: 40,000sf	Single-Family: 6,000sf Day Care Facility, Residential Facility & Temporary Shelter Facility: 8,000sf Place of Worship & School: 22,000sf Public Building & Community Center: 40,000sf
Minimum Lot Width	Single-Family & Day Care Facility: Interior Lot – 75 ft Corner Lot – 85 ft Place of Worship & School: 100 ft Public Building & Public/Private Utility: 150 ft	Single-Family, Day Care Facility, Residential Facility & Temporary Shelter Facility: Interior Lot – 50 ft Corner Lot – 60 ft Place of Worship, School, Public Building & Community Center: 100 ft
Minimum Lot Depth	Single-Family, Day Care Facility & School: 120 ft	Single-Family, Day Care Facility, Residential Facility, Temporary Shelter Facility & School: 120 ft
Maximum Lot Coverage	35%	35%
Minimum Open Space	33% total open space on zoning lot with 50% of front setback & 25% of rear setback	33% total open space on zoning lot with 50% of front setback & 25% of rear setback
Maximum FAR	0.6	Non-Residential Use: 0.6
Maximum Building Height	35 ft	35 ft
Design Guidelines	Section 13.1	Section 13.1
SETBACK REQUIREMENTS – ADDITIONAL SETBACK REQUIREMENTS IN SECTION 8.4		
Front Setback³	Single-Family: 25 ft Day Care Facility, Residential Facility, Temporary Shelter Facility, Place of Worship & School: 35 ft Public Building ⁴ & Utilities: 50 ft	Single-Family, Day Care Facility, Residential Facility & Temporary Shelter Facility: 25 ft School & Place of Worship: 35 ft Other Uses: 50 ft
Interior Side Setback³	Single-Family, Day Care Facility, Residential Facility & Temporary Shelter Facility: 10 ft Place of Worship & School: 20 ft Public Building ⁴ : 50 ft Utilities: 100 ft	Single-Family: 5 ft Day Care Facility, Residential Facility & Temporary Shelter Facility: 10 ft Place of Worship & School: 20 ft Other Uses: 50 ft
Street Side Setback³	Single-Family, Day Care Facility, Residential Facility & Temporary Shelter Facility: 15 ft Place of Worship & School: 25 ft Public Building ⁴ & Utilities: 50 ft	Single-Family: 10 ft Day Care Facility, Residential Facility & Temporary Shelter Facility: 15 ft Place of Worship & School: 25 ft Other Uses: 50 ft
Rear Setback³	Single-Family: 35 ft or 20% of lot depth, whichever is less Day Care Facility, Residential Facility, Temporary Shelter Facility, Place of Worship & School: 35 ft Public Building ⁴ : 50 ft Utilities: 100 ft	Single-Family: 35 ft or 20% of lot depth, whichever is less Day Care Facility, Residential Facility, Temporary Shelter Facility, Place of Worship & School: 35 ft Other Uses: 50 ft

TABLE 8-2: RESIDENTIAL DISTRICTS BULK AND SETBACK REGULATIONS

BULK AND SETBACK REQUIREMENTS	DISTRICT	
	R-2	R-3
BULK REQUIREMENTS		
Minimum Lot Area	Single-Family: 6,000sf Two-Family, Day Care Facility, Residential Facility & Temporary Shelter Facility: 8,000sf Place of Worship & School: 22,000sf Public Building & Community Center: 40,000sf	Single-Family: 6,000sf Two-Family: 7,200sf Lodging House, Fraternity or Sorority House: 500sf per room but no less than 6,000sf Dormitory: 600sf per room but no less than 16,000sf Multi-Family: 2,000sf per dwelling unit but no less than 10,000sf Community Center: 40,000sf Place of Worship & School: 22,000sf Public Building: 40,000sf Day Care Facility & Residential Facility: 7,200sf Temporary Shelter Facility: 400sf per bed but no less than 7,200sf
Minimum Floor Area (Dwelling Units)		Efficiency Dwelling Unit: 400sf 1-Bedroom: 540sf 2-Bedroom: 750sf 3+ Bedrooms: 750sf for first 2 bedrooms + 100sf for each additional bedroom
Minimum Lot Width	Single-Family, Two-Family, Day Care Facility, Residential Facility & Temporary Shelter Facility: Interior Lot – 50 ft Corner Lot – 60 ft Place of Worship, School, Public Building & Community Center: 100 ft	Single-Family, Two-Family, Multi-Family, Lodging House, Fraternity or Sorority House, Day Care Facility, Residential Facility & Temporary Shelter Facility: Interior Lot – 50 ft Corner Lot – 55 ft Dormitory, Community Center, Place of Worship, School & Public Building: 100 ft
Minimum Lot Depth	Single-Family, Two-Family, Day Care Facility, Residential Facility, Temporary Shelter Facility & School: 120 ft	Single-Family, Two-Family, Multi-Family, Lodging House, Fraternity or Sorority House, Day Care Facility, Residential Facility & Temporary Shelter Facility: 120 ft
Maximum Lot Coverage	30%	30%
Minimum Open Space	33% total open space on zoning lot with 50% of front setback & 25% of rear setback	33% total open space on zoning lot with 50% of front setback & 25% of rear setback
Maximum FAR	Non-Residential Use: 0.6	1.0
Minimum Building Separation		40 ft between principal buildings
Maximum Building Height	35 ft	35 ft
Design Guidelines	Section 13.1	See Section 13.1
SETBACK REQUIREMENTS – ADDITIONAL SETBACK REQUIREMENTS IN SECTION 8.4		
Front Setback ³	Single-Family, Two-Family, Day Care Facility, Residential Facility & Temporary Shelter Facility: 25 ft Place of Worship & School: 35 ft Other Uses: 50 ft	Single-Family, Two-Family, Multi-Family, Lodging House, Fraternity or Sorority House, Day Care Facility, Residential Facility, & Temporary Shelter Facility: 25 ft Dormitory, Place of Worship & School: 35 ft Other Uses: 50 ft

TABLE 8-2: RESIDENTIAL DISTRICTS BULK AND SETBACK REGULATIONS

BULK AND SETBACK REQUIREMENTS	DISTRICT	
	R-2	R-3
Interior Side Setback³	Single-Family: 5 ft Two-Family, Day Care Facility, Residential Facility & Temporary Shelter Facility: 10 ft Place of Worship & School: 20 ft Other Uses: 50 ft	Single-Family, Two-Family, Day Care Facility, Residential Facility & Temporary Shelter Facility: 10 ft Multi-Family, Lodging House, Fraternity or Sorority House, Dormitory, Place of Worship & School: 20 ft Other Uses: 50 ft
Street Side Setback³	Single-Family: 10 ft Two-Family, Day Care Facility, Residential Facility & Temporary Shelter Facility: 15 ft Place of Worship & School: 25 ft Other Uses: 50 ft	Single-Family, Two-Family, Day Care Facility, Residential Facility & Temporary Shelter Facility: 15 ft Multi-Family, Lodging House, Fraternity or Sorority House, Place of Worship & School: 25 ft Dormitory: 30 ft Other Uses: 50 ft
Rear Setback³	Single-Family: 35 ft or 20% of lot depth, whichever is less Two-Family, Day Care Facility, Residential Facility, Temporary Shelter Facility, Place of Worship & School: 35 ft Other Uses: 50 ft	Single-Family, Two-Family, Day Care Facility, Residential Facility, Temporary Shelter Facility & Place of Worship: 35 ft Multi-Family, Lodging House, Fraternity or Sorority House, Place of Worship, School & Dormitory: 40 ft Other Uses: 50 ft

TABLE 8-2: RESIDENTIAL DISTRICTS BULK AND SETBACK REGULATIONS

BULK AND SETBACK REQUIREMENTS	DISTRICT	
	R-3A	R-4
BULK REQUIREMENTS		
Minimum Lot Area	Single-Family: 6,000sf Two-Family: 7,200sf Lodging House, Fraternity or Sorority House: 700sf per room but no less than 6,000sf Multi-Family: 2,800sf per dwelling unit but no less than 10,000sf Place of Worship & School: 22,000sf Public Building: 40,000sf Day Care Facility & Residential Facility: 7,200sf Temporary Shelter Facility: 800sf per bed but no less than 7,200sf	Single-Family: 6,000sf Two-Family, Day Care Facility & Residential Facility: 8,000sf Townhouse & Multi-Family: 3,600sf per dwelling unit but no less than 12,000sf Community Center & Public Building: 40,000sf Place of Worship & School: 22,000sf Temporary Shelter Facility: 800sf per bed but no less than 8,000sf
Minimum Floor Area (Dwelling Units)	Efficiency Dwelling Unit: 400sf 1-Bedroom: 540sf 2-Bedroom: 750sf 3+ Bedrooms: 750sf for first 2 bedrooms + 100sf for each additional bedroom	Efficiency Dwelling Unit: 400sf 1-Bedroom: 540sf 2-Bedroom: 750sf 3+ Bedrooms: 750sf for first 2 bedrooms + 100sf for each additional bedroom
Minimum Lot Width	Single-Family, Two-Family, Multi-Family, Lodging House, Fraternity or Sorority House, Day Care Facility, Residential Facility & Temporary Shelter Facility: Interior Lot – 50 ft Corner Lot – 55 ft Place of Worship, School & Public Building: 100 ft	Single-Family, Two-Family, Day Care Facility, Residential Facility & Temporary Shelter Facility: Interior Lot – 50 ft Corner Lot – 60 ft Townhouse & Multi-Family: 75 ft Community Center, Place of Worship, School & Public Building: 100 ft
Minimum Lot Depth	Single-Family, Two-Family, Multi-Family, Lodging House, Fraternity or Sorority House, Day Care Facility, Residential Facility & Temporary Shelter Facility: 120 ft	Single-Family, Two-Family, Multi-Family, Townhouse, Day Care Facility, Residential Facility, Temporary Shelter Facility & School: 120 ft
Maximum Lot Coverage	30%	30%
Minimum Open Space	33% total open space on zoning lot with 50% of front setback & 25% of rear setback	33% total open space on zoning lot with 50% of front setback & 25% of rear setback
Maximum FAR	0.7	0.6
Minimum Building Separation	40 ft between principal buildings	40 ft between principal buildings on the same zoning lot 10 ft between townhouses on the same zoning lot
Maximum Building Height	35 ft	35 ft
Design Guidelines	See Section 13.1	See Section 13.1
SETBACK REQUIREMENTS – ADDITIONAL SETBACK REQUIREMENTS IN SECTION 8.4		
Front Setback³	Single-Family, Two-Family, Multi-Family, Lodging House ⁵ , Fraternity or Sorority House ⁵ , Day Care Facility, Residential Facility & Temporary Shelter Facility: 25 ft Place of Worship & School: 35 ft Other Uses: 50 ft	Single-Family, Two-Family, Townhouse, Multi-Family, Day Care Facility, Residential Facility, Temporary Shelter Facility, Place of Worship & School: 35 ft Other Uses: 50 ft
Interior Side Setback³	Single-Family, Two-Family, Day Care Facility, Residential Facility & Temporary Shelter Facility: 10 ft	Single-Family, Two-Family, Day Care Facility, Residential Facility & Temporary Shelter Facility: 10 ft

TABLE 8-2: RESIDENTIAL DISTRICTS BULK AND SETBACK REGULATIONS		
BULK AND SETBACK REQUIREMENTS	DISTRICT	
	R-3A	R-4
	Multi-Family, Lodging House ⁵ , Fraternity or Sorority House ⁵ , Place of Worship & School: 20 ft Other Uses: 50 ft	Multi-Family, Townhouse, Place of Worship & School: 20 ft Other Uses: 50 ft
Street Side Setback ³	Single-Family, Two-Family, Day Care Facility, Residential Facility & Temporary Shelter Facility: 15 ft Multi-Family, Lodging House ⁵ , Fraternity or Sorority House ⁵ , Place of Worship & School: 25 ft Other Uses: 50 ft	Single-Family, Two-Family, Day Care, Residential Facility & Temporary Shelter Facility: 15 ft Multi-Family & Townhouse: 30 ft Place of Worship & School: 25 ft Other Uses: 50 ft
Rear Setback ³	Single-Family, Two-Family, Day Care Facility, Residential Facility, Temporary Shelter Facility & Place of Worship: 35 ft Multi-Family, Lodging House ⁵ , Fraternity or Sorority House ⁵ , Place of Worship & School: 40 ft Other Uses: 50 ft	Single-Family, Two-Family, Day Care Facility, Residential Facility, Temporary Shelter Facility, Place of Worship & School: 35 ft Multi-Family & Townhouse: 40 ft Other Uses: 50 ft

TABLE 8-2: RESIDENTIAL DISTRICTS BULK AND SETBACK REGULATIONS

BULK AND SETBACK REQUIREMENTS	DISTRICT	
	R-5	R-6
BULK REQUIREMENTS		
Minimum Lot Area	Single-Family: 6,000sf Two-Family, Day Care Facility & Residential Facility: 8,000sf Townhouse: 2,800sf per dwelling unit but no less than 12,000sf Multi-Family: 2,000sf per dwelling unit but no less than 10,000sf Community Center & Public Building: 40,000sf Place of Worship & School: 22,000sf Temporary Shelter Facility: 400sf per bed but no less than 8,000sf	Single-Family: 6,000sf Two-Family, Day Care Facility & Residential Facility: 8,000sf Townhouse: 2,800sf per dwelling unit but no less than 12,000sf Multi-Family: 2,000sf per dwelling unit but no less than 10,000sf Dormitory, Nursing Home & Convalescent Home: 620sf per dwelling unit but no less than 16,000sf Community Center & Public Building: 40,000sf Place of Worship & School: 22,000sf Temporary Shelter Facility: 400sf per bed but no less than 8,000sf
Minimum Floor Area (Dwelling Units)	Efficiency Dwelling Unit: 400sf 1-Bedroom: 540sf 2-Bedroom: 750sf 3+ Bedrooms: 750sf for first 2 bedrooms + 100sf for each additional bedroom	Efficiency Dwelling Unit: 400sf 1-Bedroom: 540sf 2-Bedroom: 750sf 3+ Bedrooms: 750sf for first 2 bedrooms + 100sf for each additional bedroom
Minimum Lot Width	Single-Family, Two-Family, Day Care Facility, Residential Facility & Temporary Shelter Facility: Interior Lot – 50 ft Corner Lot – 60 ft Townhouse & Multi-Family: 75 ft Community Center, Place of Worship, School & Public Building: 100 ft	Single-Family, Two-Family, Day Care Facility, Residential Facility & Temporary Shelter Facility: Interior Lot – 50 ft Corner Lot – 60 ft Townhouse, Multi-Family, Dormitory, Nursing Home & Convalescent Home: 75 ft Community Center, Place of Worship, School & Public Building: 100 ft
Minimum Lot Depth	Single-Family, Two-Family, Multi-Family, Townhouse, Day Care Facility, Residential Facility, Temporary Shelter Facility & School: 120 ft	Single-Family, Two-Family, Multi-Family, Townhouse, Day Care Facility, Residential Facility, Temporary Shelter Facility & School: 120 ft
Maximum Lot Coverage	30%	40%
Minimum Open Space	33% total open space on zoning lot with 50% of front setback & 25% of rear setback	33% total open space on zoning lot with 50% of front setback & 25% of rear setback
Maximum FAR	0.7	1.5
Minimum Building Separation	40 ft between principal buildings 10 ft between townhouses	40 ft between principal buildings 10 ft between townhouses
Maximum Building Height	45 ft	45 ft
Design Guidelines	See Section 13.1	See Section 13.1
SETBACK REQUIREMENTS – ADDITIONAL SETBACK REQUIREMENTS IN SECTION 8.4		
Front Setback³	Single-Family, Two-Family, Townhouse, Multi-Family, Day Care Facility, Residential Facility, Temporary Shelter Facility, Place of Worship & School: 35 ft Other Uses: 50 ft	Single-Family, Two-Family, Townhouse, Multi-Family, Dormitory, Nursing Home, Convalescent Home, Day Care Facility, Residential Facility, Temporary Shelter Facility, Place of Worship & School: 35 ft Other Uses: 50 ft

TABLE 8-2: RESIDENTIAL DISTRICTS BULK AND SETBACK REGULATIONS		
BULK AND SETBACK REQUIREMENTS	DISTRICT	
	R-5	R-6
SETBACK REQUIREMENTS – ADDITIONAL SETBACK REQUIREMENTS IN SECTION 8.4		
Interior Side Setback³	Single-Family, Two-Family, Day Care Facility, Residential Facility & Temporary Shelter Facility: 10 ft Multi-Family, Townhouse, Place of Worship & School: 20 ft Other Uses: 50 ft	Single-Family, Two-Family, Day Care Facility, Residential Facility & Temporary Shelter Facility: 10 ft Multi-Family, Townhouse, Dormitory, Nursing Home, Convalescent Home, Place of Worship & School: 20 ft Other Uses: 50 ft
Street Side Setback³	Single-Family, Two-Family, Day Care, Residential Facility & Temporary Shelter Facility: 15 ft Multi-Family & Townhouse: 30 ft Place of Worship & School: 25 ft Other Uses: 50 ft	Single-Family, Two-Family, Day Care Facility, Residential Facility & Temporary Shelter Facility: 15 ft Multi-Family, Townhouse, Dormitory, Nursing Home, Convalescent Home, Place of Worship & School: 30 ft Other Uses: 50 ft
Rear Setback³	Single-Family, Two-Family, Day Care Facility, Residential Facility, Temporary Shelter Facility, Place of Worship & School: 35 ft Multi-Family & Townhouse: 40 ft Other Uses: 50 ft	Single-Family, Two-Family, Day Care Facility, Residential Facility, Temporary Shelter Facility, Place of Worship & School: 35 ft Multi-Family, Townhouse, Dormitory, Nursing Home & Convalescent Home: 40 ft Other Uses: 50 ft

TABLE 8-2: RESIDENTIAL DISTRICTS BULK AND SETBACK REGULATIONS	
BULK AND SETBACK REQUIREMENTS	DISTRICT
	R-7
BULK REQUIREMENTS	
Minimum Lot Area	Single-Family: 6,000sf Two-Family, Day Care Facility & Residential Facility: 8,000sf Townhouse: 2,100sf per dwelling unit but no less than 12,000sf Multi-Family: 1,500sf per dwelling unit but no less than 10,000sf Community Center & Public Building: 40,000sf Place of Worship & School: 22,000sf Temporary Shelter Facility: 400sf per bed but no less than 8,000sf
Minimum Floor Area (Dwelling Units)	Efficiency Dwelling Unit: 400sf 1-Bedroom: 540sf 2-Bedroom: 750sf 3+ Bedrooms: 750sf for first 2 bedrooms + 100sf for each additional bedroom
Minimum Lot Width	Single-Family, Two-Family, Day Care Facility, Residential Facility & Temporary Shelter Facility: Interior Lot – 50 ft Corner Lot – 60 ft Townhouse & Multi-Family: 75 ft Community Center, Place of Worship, School & Public Building: 100 ft
Minimum Lot Depth	Single-Family, Two-Family, Multi-Family, Townhouse, Day Care Facility, Residential Facility, Temporary Shelter Facility & School: 120 ft
Maximum Lot Coverage	40%
Minimum Open Space	33% total open space on zoning lot with 50% of front setback & 25% of rear setback
Maximum FAR	3.5
Minimum Building Separation	40 ft between principal buildings 10 ft between townhouses
Maximum Building Height	70 ft
Design Guidelines	See Section 13.1
SETBACK REQUIREMENTS – ADDITIONAL SETBACK REQUIREMENTS IN SECTION 8.4	
Front Setback ³	Single-Family, Two-Family, Townhouse, Multi-Family, Day Care Facility, Residential Facility, Temporary Shelter Facility, Place of Worship & School: 35 ft Other Uses: 50 ft
Interior Side Setback ³	Single-Family, Two-Family, Day Care Facility, Residential Facility & Temporary Shelter Facility: 10 ft Multi-Family, Townhouse, Place of Worship & School: 20 ft Other Uses: 50 ft
Street Side Setback ³	Single-Family, Two-Family, Day Care Facility, Residential Facility & Temporary Shelter Facility: 15 ft Multi-Family & Townhouse: 30 ft Place of Worship & School: 25 ft Other Uses: 50 ft
Rear Setback ³	Single-Family, Two-Family, Day Care Facility, Residential Facility, Temporary Shelter Facility, Place of Worship & School: 35 ft Multi-Family & Townhouse: 40 ft Other Uses: 50 ft

FOOTNOTES TABLE 8-2

¹ Animal density allowances are calculated using gross acreage of all substantially contiguous property owned or leased by the same property owner regardless of jurisdictional boundary and rounded up to the nearest whole number.

² All properties with livestock must have a Waste Utilization Plan (according to NRCS Standard 633) that is approved by the applicable county soil and water conservation district and comply with all MPCA permitting requirements.

³ Setbacks in the residential districts are subject to the requirements of Section 8.4.

⁴ Includes civic and cultural buildings.

⁵ Principal structures containing a lodging house and fraternity or sorority houses constructed prior to July 1, 1990 are permitted to use the existing setbacks. Any addition must comply with the setback requirements of Table 8-2.

8.4 ADDITIONAL SETBACK REQUIREMENTS

A. Front Setback

1. When more than twenty-five percent (25%) of the blockface on the side of the street between intersections is occupied by structures having setbacks less than the minimum setback required by this Code, the minimum required setback for all new or relocated structures is the average of all existing buildings on the blockface. See Figure 8-1: Front Setback Averaging.

FIGURE 8-1: FRONT SETBACK AVERAGING

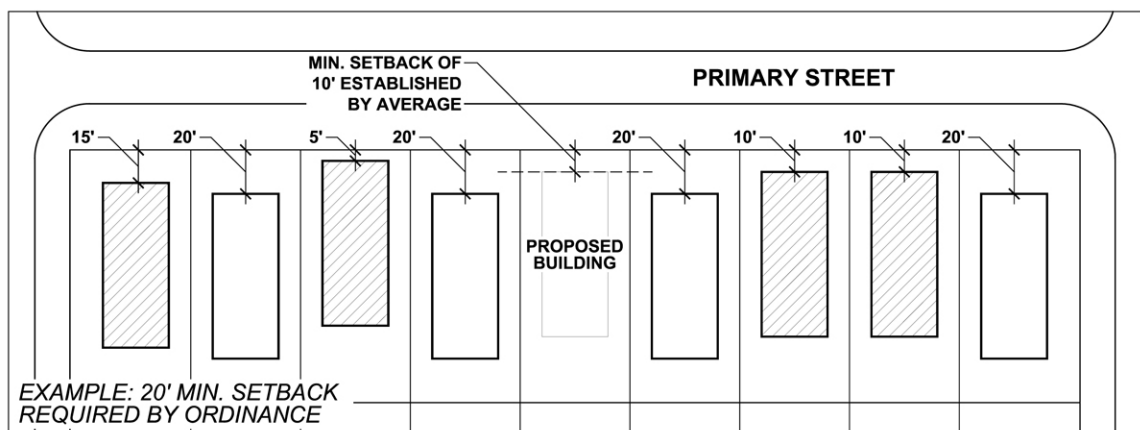

2. For new structures, when there is an established setback different from the minimum required setback, and there are existing buildings on both sides, the front setback will be no greater than that which would be established by connecting a straight line between the forward-most portions of the adjacent building on either side. This provision does not apply to multi-family dwellings, lodging houses, and fraternity and sorority houses in the R-3 District. See Figure 8-2: Established Front Setback.

FIGURE 8-2: ESTABLISHED FRONT SETBACK

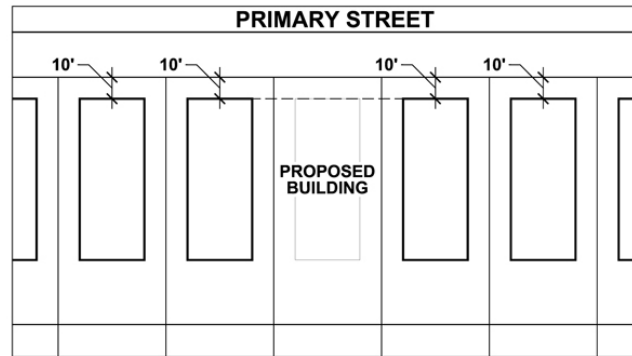

B. Street Side Setback

1. When there is an adjoining lot facing onto the side street, the side street setback must be increased from the required minimum setback to that of the required front setback (See [Figure 8-3: Street Side Setback – Reverse Corner Lot](#)).

FIGURE 8-3: STREET SIDE SETBACK – REVERSE CORNER LOT

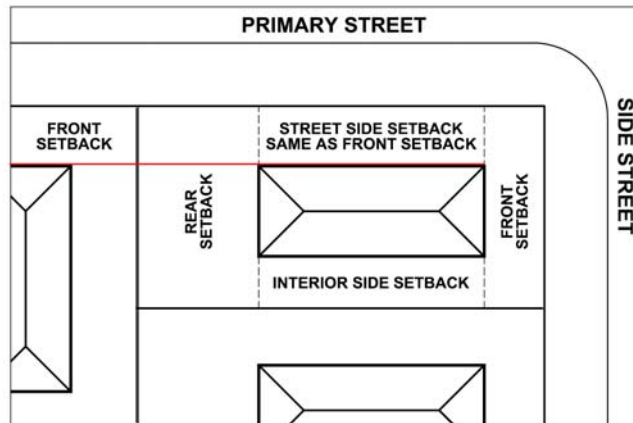

2. In residential districts, where a garage fronts onto a side street, the minimum setback must be twenty (20) feet. (See [Figure 8-4: Street Side Setback – Side Street Garage Access](#))

FIGURE 8-4: STREET SIDE SETBACK – SIDE STREET GARAGE ACCESS

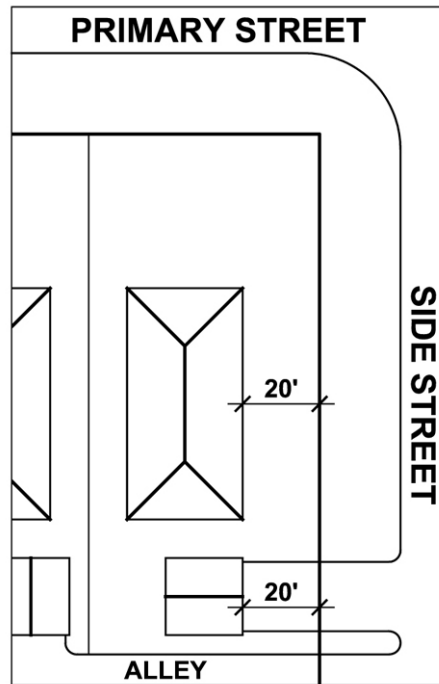

C. Interior Side Setback

1. Substandard Lot of Record

For a substandard lot of record with a single-family or two-family dwelling, the minimum interior side setback may be reduced to twenty percent (20%) of the lot width, except for single-family dwellings in the R-2 District where the interior side yard setback must be a minimum of five (5) feet. However, in no case, the interior side setback must be no less than five (5) feet and the street side setback must be no less than ten (10) feet.

2. Building Height Setback

If the structure is greater than seventeen (17) feet in height, the interior side setback requires an additional foot of setback for each two (2) feet of structure height over seventeen (17) feet. In the case where a lot is occupied by a single-family or two-family dwelling with a side yard setback less than what is required in this section, the existing dwelling unit structure establishes the side yard setback, except, in no case, the interior side setback must be no less than five (5) feet.

D. Rear Setback

1. Substandard Lot of Record

Where a lot of record has less than the minimum depth required, thirty-three percent (33%) of the total lot depth is required as rear yard.

2. Building Height Setback

In such case where a multi-family structure exceeds thirty-five (35) feet in height, an additional rear setback of one-half (0.5) foot is required for each foot of vertical building height over thirty-five (35) feet.

E. Pipeline Setback

1. The purpose of this provision is to increase public safety by requiring that new development be set back from pipeline locations. This requirement applies to new residential and other development. It does not apply to development that has occurred or for which development permits have been issued before the effective date of this requirement.
2. Buildings and places of assembly may not be constructed closer to the pipeline than the boundary of the pipeline easement.

8.5 GENERAL STANDARDS OF APPLICABILITY

A. Accessory Structures and Uses

See Section 15.5 (Accessory Structures and Uses) for standards governing accessory structures and uses.

B. Temporary Uses

See Section 14.4 (Temporary Uses) for standards governing temporary uses.

C. On-Site Development Standards

See Article 15 (On-Site Development Standards) for on-site development standards.

D. Off-Street Parking and Loading

See Article 16 (Off-Street Parking and Loading) for standards governing off-street parking and loading.

E. Landscaping and Screening

See Article 17 (Landscaping, Buffering and Screening) for standards governing landscaping and screening.

F. Signs

See Article 18 (Signs) for standards governing signs.